

AC Power Input EtherCAT Comm. Type 2-Phase Closed-loop Stepper Motor Driver



AiCA-D-EC Series PRODUCT MANUAL

For your safety, read and follow the considerations written in the instruction manual, other manuals and Autonics website.

The specifications, dimensions, etc. are subject to change without notice for product improvement. Some models may be discontinued without notice.

Features

- Closed-loop system with real-time position control
- High speed & high torque drive without missing steps
- Supports 200 - 240 VAC~ AC power
- Multi-axis simultaneous control with EtherCAT communication
- Windows-based software (atMotion) for easy parameter setting and monitoring
- 7-segment display for alarm / status reading
- Supports torque mode
- Supports Auto Current Down mode
- Built-in brake type motors available (AiCA-D-B-EC Series)
- Built-in geared/rotary actuator type motors available

Safety Considerations

- Observe all 'Safety Considerations' for safe and proper operation to avoid hazards.
- ⚠ symbol indicates caution due to special circumstances in which hazards may occur.

⚠ Warning Failure to follow instructions may result in serious injury or death.

- 01. Fail-safe device must be installed when using the unit with machinery that may cause serious injury or substantial economic loss. (e.g. nuclear power control, medical equipment, ships, vehicles, railways, aircraft, combustion apparatus, safety equipment, crime / disaster prevention devices, etc.)**
Failure to follow this instruction may result in personal injury, economic loss or fire.
- 02. Do not use the unit in the place where flammable / explosive / corrosive gas, high humidity, direct sunlight, radiant heat, vibration, impact or salinity may be present.**
Failure to follow this instruction may result in explosion or fire.
- 03. Do not connect, repair, or inspect the unit while connected to a power source.**
Failure to follow this instruction may result in fire or electric shock.
- 04. Install the unit after considering counter plan against power failure.**
Failure to follow this instruction may result in personal injury, economic loss or fire.
- 05. Re-supply power after min. 20 sec from disconnected power.**
It may cause damage or malfunction of the product
- 06. Check 'Connections' before wiring.**
Failure to follow this instruction may result in fire.
- 07. For installing the unit, ground it exclusively and use over AWG 18 (0.75 mm²) ground cable.**
Failure to follow this instruction may result in electric shock.
- 08. Do not disassemble or modify the unit.**
Failure to follow this instruction may result in fire or electric shock.
- 09. Insulate the connector not to be exposed.**
Failure to follow this instruction may result in electric shock.
- 10. Install the driver in the housing or ground it.**
Failure to follow this instruction may result in personal injury, fire or electronic shock.
- 11. Do not touch the unit during or after operation for a while.**
Failure to follow this instruction may result in burn or electric shock due to high temperature of the surface.
- 12. Do not remove the connector during or after operation for a while.**
Failure to follow this instruction may result in electric shock, or product damage.
- 13. Emergency stop directly when error occurs.**
Failure to follow this instruction may result in personal injury or fire.

⚠ Caution Failure to follow instructions may result in injury or product damage.

- 01. When connecting the power input, use AWG18 (0.75 mm²) cable or over.**
- 02. Brake is non-polar. When connecting the brake, use AWG24 (0.2 mm²) cable or over.**
Failure to follow this instruction may result in fire or malfunction due to contact failure.
- 03. To use the motor safely, do not apply external force to the motor.**
- 04. It is recommended to use STOPPER for the vertical load.**
- 05. Install over-current prevention device (e.g. the current breaker, etc.) to connect the driver with power.**
Failure to follow this instruction may result in fire.
- 06. Check the control input signal before supplying power to the driver.**
Failure to follow this instruction may result in personal injury or product damage by unexpected driver movement.
- 07. Install a safety device to maintain the vertical position after turn off the power of this driver.**
Failure to follow this instruction may result in personal injury or product damage by releasing holding torque of the motor.
- 08. Use the unit within the rated specifications.**
Failure to follow this instruction may result in fire or product damage.
- 09. Use a dry cloth to clean the unit, and do not use water or organic solvent.**
Failure to follow this instruction may result in fire or electric shock.
- 10. The driver may overheat depending on the environment. Install the unit at the well-ventilated environment and forced cooling with a cooling fan.**
Failure to follow this instruction may result in product damage or degradation by heat.
- 11. Keep the product away from metal chip, dust, and wire residue which flow into the unit.**
Failure to follow this instruction may result in fire or product damage.
- 12. Use the designated motor only.**
Failure to follow this instruction may result in fire or product damage.

Cautions during Use

- Follow instructions in 'Cautions during Use'. Otherwise, it may cause unexpected accidents.
- Install vertically so that the status display part is located on top.
- In case of unwanted noise generating from peripherals and power, use ferrite core in the wiring.
- The thickness of cable should be same or thicker than the below specifications when connecting the cable for connector.
 - Motor + Encoder connector: AWG22
 - Power connector: AWG18
 - I/O connector: AWG28
 - Brake connector: AWG22
- Keep the distance between power cable and signal cable over 10 cm.
- Do not input external signal until the driver is initialized (In-Position LED ON) after power is applied.
- Motor vibration and noise may occur in a specific frequency range.
 - Change the motor installation method or attach the damper.
 - Use the unit out of the corresponding frequency range due to changing motor RUN speed.
- Maintain and inspect regularly the following lists.
 - Unwinding bolts and connection parts for the unit installation and load connection
 - Abnormal sound from ball-bearing of the unit
 - Damage and stress of lead cable of the unit
 - Connection error with motor
 - Inconsistency between the axis of motor output and the center, concentric (eccentric, declination) of the load, etc.
- This product does not contain a protection function for a motor unit.
- This unit may be used in the following environments.
 - Indoors (in the environment condition rated in 'Specifications')
 - Altitude max. 2,000 m
 - Pollution degree 2
 - Installation category II

Cautions during Installation

- Install on the metal plate with high thermal conductivity for heat dissipation of the driver.
- Install in the well-ventilated area and install the cooling fan in the unventilated environment.
- Failure to heat dissipation may result in damage or malfunction due to the stress on the product. Check the environment of use within the specifications and install on the well-heat dissipated area
- In case of installing the drivers more than two, keep distance at least 20 mm in horizontal direction and at least 25 mm in vertical direction.

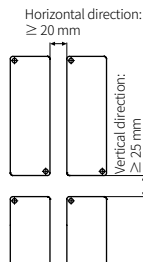

Ordering Information

This is only for reference, the actual product does not support all combinations. For selecting the specified model, follow the Autonics website. Select a model that matches the ordering information of the motor and the driver.

AiCA - D - ① ② ③ - ④ - EC

① Frame size

Number: Frame size (mm)

② Axial length

M: Medium

L: Long

③ Encoder resolution

A: 10,000 PPR (2,500 PPR × 4-multiply)

④ Motor type

No mark: Standard type

B: Built-in brake type

Product Components

- Product
- Instruction manual
- Power connector × 1
- I/O connector × 1
- Brake connector (AiCA-D-B-EC Series) × 1

Manual

For proper use of the product, refer to the manuals and be sure to follow the safety considerations in the manuals. Download the manuals from the Autonics website.

Sold Separately

- I/O cable: CO20-MP□-R (specifications: AiC-EC TAG)
- Motor + Encoder cable: C1D14M(B)-□ (fixed type), C1DF14M(B)-□ (flexible type)

Software

Download the installation file and the manuals from the Autonics website.

■ atMotion

The program allows to manage the motor driver's parameter setting and monitoring data.

Dimensions

- Unit: mm, For the detailed drawings, follow the Autonics website.

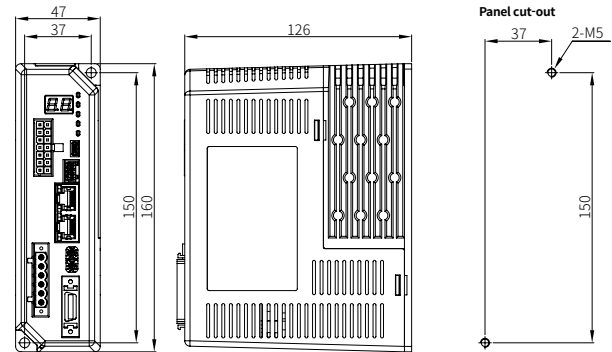

Unit Descriptions

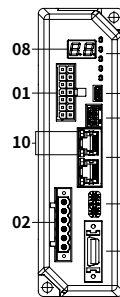

- Motor + Encoder connector
- Power connector
- Comm. connector
- I/O connector
- Brake connector (AiCA-D-B-EC Series)
- USB connector
- Comm. ID setting rotary switch
- Status display part
- Status indicators
- Comm. indicator

Status Display Part / Indicators

Display part / Indicator	Color	Descriptions
Status display part (7-segment)	Red	Displays EtherCAT ID Displays the corresponding number, operation when alarm / warning occurs
Power / Alarm indicator (PWR/AL)	Green	Turns ON when the unit operates in normal after power is applied Flashes depending on the warning type
	Red	Flashes depending on the alarm type
In-Position indicator (INP)	Yellow	Turns ON when motor is placed at command position after positioning input
Servo ON / OFF indicator (SERVO)	Blue	Turns ON when Servo ON, turns OFF when Servo OFF
EtherCAT comm. error indicator (ERR)	Red	Flashes depending on communication fail status
EtherCAT comm. operation indicator (RUN)	Green	Flashes depending on communication normal status

Alarm / Warning

The status display part displays segment depending on Alarm / Warning type. Depending on the alarm / warning type, it flashes for 0.4 sec interval and it turns OFF for 0.8 sec repeatedly. For more information of Alarm / Warning, refer to 'User manual'.

■ Alarm

Display	Alarm type	Display	Alarm type
E.5	EtherCAT comm. error	E.F	Speed command error
E.1	Overcurrent error	E.b	Lack of voltage error
E.2	Overspeed error	E.C	In-Position error
E.3	Position tracking error	E.d	Memory error
E.4	Overload error	E.E	Emergency stop
E.5	Overheat error	E.H	Home search error
E.6	Motor connection error	E.J	Brake connection error
E.7	Encoder connection error	E.L	PDO allocation error
E.8	Overvoltage error	-	-
E.9	Motor alignment error	-	-

■ Warning

Display	Warning type
W.1	+Software limit
W.2	-Software limit
W.3	+Hardware limit
W.4	-Hardware limit
W.5	Overload warning

Specifications

Model	AiCA-D-60MA-□-EC	AiCA-D-60LA-□-EC	AiCA-D-86MA-□-EC	AiCA-D-86LA-□-EC
Main power	Power supply	200 - 240 VAC~ 50/60 Hz		
	Max. RUN power ⁰¹⁾	≤ 800 VA		
	Stop power ⁰²⁾	≤ 60 VA	≤ 65 VA	
AUX power ⁰³⁾	Power supply	24 VDC≐		
	Input current	0.3 A	0.5 A	
Max. RUN current ⁰⁴⁾	2.0 A / Phase			
Stop current	20 to 100% of max. RUN current			
Resolution	500, 1000, 1600, 2000, 3200, 3600, 5000, 6400, 7200, 10000 (factory default) PPR			



01) When changing the load rapidly, instantaneous peak current may increase. The capacity of power supply should be over 1.5 to 2 times of max. RUN power.

02) Based on ambient temp. 25 °C, ambient humi. 55 %RH, stop current 20%

03) Auxiliary power is only available in built-in brake type and not available in standard type.

04) RUN current varies depending on the input RUN frequency and max. RUN current at the moment varies also.

Run method	2-phase bipolar closed-loop control method
Speed filter	Disable, 2, 4, 6, 8, 10, 20, 40, 60(factory default), 80, 100, 120, 140, 160, 180, 200 ms
Control Gain	0 (factory default) to 31, (31: Fine Gain)
Max. rotation speed	3,000 rpm
In-Position	Fast Response: 0 to 7 (factory default), Accurate Response: 0 to 7
Operation mode	CSP, CSV, CST, PP, PV, HM
Home search	Homing on the negative limit switch and index pulse Homing on the positive limit switch and index pulse Homing on the home switch and index pulse (Positive) Homing on the home switch and index pulse (Negative) Homing without an index pulse (negative limit switch) Homing without an index pulse (positive limit switch) Homing without an index pulse (Positive and Home sensor ON) Homing without an index pulse (Negative and Home sensor ON) Homing on the index pulse (Negative) Homing on the index pulse (Positive) Set the Origin with Home offset Set the Origin and Reset Current Position Torque Homing Search- with Home offset Torque Homing Search+ with Home offset

Input	Exclusive input: 7, General input: 5
Output	Exclusive output: 2 General output: 4
External power supply	VEX (Default: 24 VDC≐), GEX (GND)
Input resistance	4.7 kΩ (Anode Pull-Up)
Insulation resistance	≥ 200 MΩ (500 VDC≐ megger)
Dielectric strength	Between the all charging part and the case: 1,500 VAC~ 60 Hz for 1 minute
Vibration	1.5 mm double amplitude at frequency 10 to 55 Hz in each X, Y, Z direction for 2 hours
Shock	300 m/s ² (≈ 30 G) in each X, Y, Z direction for 3 times
Ambient temp.	0 to 50°C, storage: -10 to 60°C (no freezing or condensation)
Ambient humi.	35 to 85%RH, storage: 10 to 90%RH (no freezing or condensation)
Protection rating	IP20 (IEC standard)
Certification	CE  
Unit weight (packaged)	≈ 770 g (≈ 1,040 g)

Communication Interface

■ EtherCAT

Comm. specifications	EtherCAT
Association approval ⁰¹⁾	
Support protocol	CoE (support CiA402 profile), support FoE
Physical layer	100BASE-TX (IEEE802.3)
Connection cable	CAT5e class or over (Shield type: SF/FTP, S/FTP, SF/UTP)
Max. comm. distance	Within 100 m distance between nodes
Baud rate	10 / 100 Mbps
Distributed clock	DC cycle: 250 us, 500 us, 1 ms, 2 ms, 4 ms, 8 ms
Node ID setting	ECAT ID switch setting: 1 to 99 Physical address setting at Master: 1 to 65535
Topology	Star, Line, Tree

01) EtherCAT® is registered trademark and patented technology, licensed by Beckhoff Automation GmbH, Germany.

Power Supply Configuration Diagram

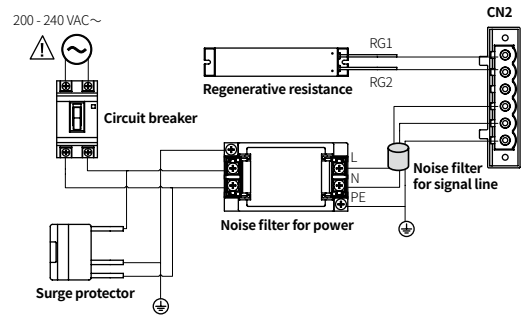

■ Noise filter for signal line

Connect to wiring to suppress external noise.
Depending on frequency, filtered noise may differ.

Type	Model	Manufacture
Motor line, I/O signal line	28A5776-0A2	Lairdtech
Power line	28A5131-0A2	
Communication line	28A2025-0A2	

■ Noise filter for power

Connect the power to suppress external noise.
The wires should be connected as short as possible and grounded.

Model	Specifications	Manufacture
RNS-2006	Rated voltage: 250 V Rated current: 6 A Max. leakage current: 1 mA	Orient Electronics

■ Regenerative resistance

Connect the pin 1, 2 on the power connector.
Use in condition of the high inertia load or the short deceleration time.
Forced cooling is required in condition of high surface temperature of regenerative resistance.

Model	Specifications	Manufacture
IRC100	Resistance: 100 Ω ±5%, Rated power: 60 W (standby), 100 W (heatsink attached)	Rara Electronics Corp.

■ Surge protector

Protect the product from external noise and surge by connecting power.
Be sure to disconnect the surge protector when testing internal pressure.
It may result in product damage.

Model	Specifications	Manufacture
LT-C12G801W	Nominal discharge current: 2500 A Max. discharge current: 5000 A Voltage protection level: 1.5 kV	OTOWA Electric Co. Ltd

Troubleshooting

Malfunction	Causes	Troubleshooting
When communication is not connected	The communication cable is not connected.	Check communication cable wiring. Check communication cable connected correctly.
	XML file does not match.	Check provided XML file is correct.
When motor does not excite at operation enable status	Hold Off signal input.	Check the Hold Off input signal. In case of ON, Servo is OFF and excitation of the motor is released.
	Alarm occurs.	Check the alarm type and remove the cause.
When motor rotates to the opposite direction of the designated direction	Polarity parameter setting is not correct.	Check the Polarity parameter settings.
	Connection between motor and encoder is unstable.	Check the driver and motor are connected correctly.
When motor drives unstable	Control Gain value is not correct.	Change the Control Gain parameter as the appropriate value.

Connectors

Motor + Encoder connector (CN1) ■ Power connector (CN2)

Pin	Function	Pin	Function
1	GND	8	+5 VDC≐
2	Encoder A	9	Encoder \bar{A}
3	Encoder B	10	Encoder \bar{B}
4	Encoder Z	11	Encoder \bar{Z}
5	PE	12	N-C
6	Motor A	13	Motor B
7	Motor \bar{A}	14	Motor \bar{B}

■ EtherCAT communication connector (CN3)

Pin	Function	Pin	Function
1	TD+	5	N-C
2	TD-	6	RD-
3	RD+	7	N-C
4	N-C	8	N-C

■ I/O connector (CN4)

Pin	Function	Pin	Function
1	VEX	11	IN3
2	ORG	12	IN4
3	+Limit	13	IN5
4	-Limit	14	In-Position
5	Alarm Reset	15	Alarm
6	Hold Off	16	OUT1
7	Stop	17	OUT2
8	EMG	18	OUT3
9	IN1	19	OUT4
10	IN2	20	GEX

■ Brake connector (CN5)

- Only available in built-in brake type.

Pin	Function
1	24 VDC≐
2	GND
3	Brake+
4	Brake-

■ USB connector (USB)

Pin	Function	Pin	Function
1	V BUS	4	N-C
2	Data -	5	GND
3	Data +	-	-

■ Suitable specifications

- The following connectors can be used with equivalent or substitute.
- EtherCAT dedicated cable must be used and the performance can not be guaranteed when using other cables.

Type	Connector specifications	Manufacture
CN1	Motor + Encoder connector 5557-14R, connector terminal: 5556T	Molex
CN2	Power connector 5ESDVM-06P-OR	Dinkle
CN3	EtherCAT comm. connector RJ45	-
CN4	I/O connector 10120-3000PE, Housing: 10320-52F0-008	3M
CN5	Brake connector ESC250V-S2330704P	Dinkle
USB	USB connector Mini USB Type B	-

Switch

■ Communication ID setting rotary switch

Setting	Address (×10)	Address (×1)
0	0×10	0
1	1×10	1
2	2×10	2
3	3×10	3
4	4×10	4
5	5×10	5
6	6×10	6
7	7×10	7
8	8×10	8
9	9×10	9

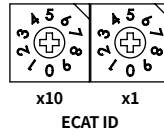

Connections

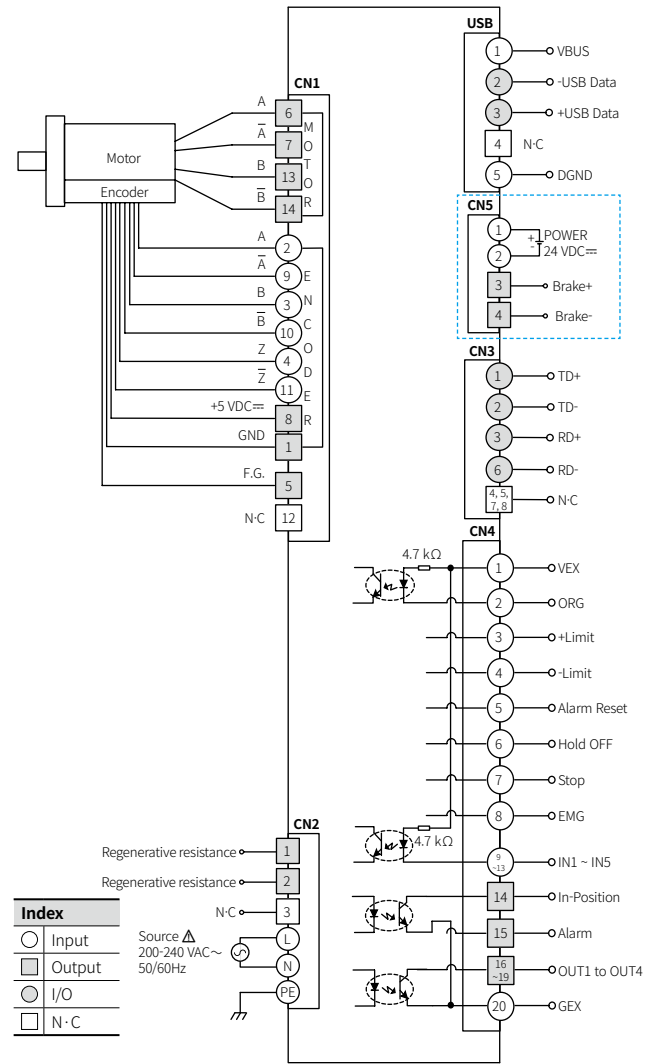

- is only available in built-in brake type.

Sold Separately : Motor + Encoder Cable

■ Fixed type: C1D14M-□, Flexible type: C1DF14M-□

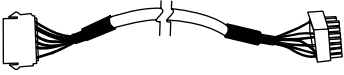

- Recommended to use ferrite core at both ends of the cable.
- The model name is 1, 2, 3, 5, 7, 10, 15, 20 which indicates the cable length.
E.g.) C1DF14M-10: 10 m flexible type Motor + Encoder cable
- For built-in brake type, use dedicated cable.
(fixed type: C1D14MB-□, flexible type: C1DF14MB-□)

Sold Separately : I/O Cable

■ CO20-MP□-R (Specifications: AiC-EC TAG)

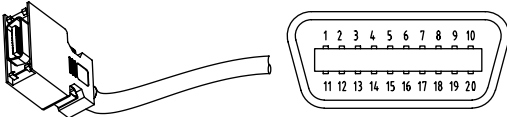

Pin	Function (Name TAG)	Cable Color	Dot line color-number
1	VEX	Yellow	Black-1
2	ORG		Red-1
3	+Limit		Black-2
4	-Limit		Red-2
5	Alarm Reset		Black-3
6	Hold Off		Red-3
7	Stop		Black-4
8	EMG		Red-4
9	IN1		Black-5
10	IN2		Red-5
11	IN3	White	Black-1
12	IN4		Red-1
13	IN5		Black-2
14	In-Position		Red-2
15	Alarm		Black-3
16	OUT1		Red-3
17	OUT2		Black-4
18	OUT3		Red-4
19	OUT4		Black-5
20	GEX		Red-5

- Recommended to use ferrite core at both ends of the cable.
- The model name is 010, 020, 030, 050, 070, 100, 150, 200 which indicates the cable length.
E.g.) CO20-MP070-R: 7 m I/O cable