

Built-in Gear / Rotary Actuator Type 2-Phase Closed-loop Stepper Motor (□ 42 mm, □ 60 mm)



Ai-M-G / Ai-M-R Series

PRODUCT MANUAL

For your safety, read and follow the considerations written in the instruction manual, other manuals and Autonics website.

The specifications, dimensions, etc. are subject to change without notice for product improvement. Some models may be discontinued without notice.

Features

- Built-in planetary gear type motor (Ai-M-G)
- Built-in rotary actuator type motor (Ai-M-R)
- Supports □ 42 mm, □ 60 mm

Safety Considerations

- Observe all 'Safety Considerations' for safe and proper operation to avoid hazards.
- ⚠ symbol indicates caution due to special circumstances in which hazards may occur.

⚠ Warning Failure to follow instructions may result in serious injury or death.

- 01. Fail-safe device must be installed when using the unit with machinery that may cause serious injury or substantial economic loss. (e.g. nuclear power control, medical equipment, ships, vehicles, railways, aircraft, combustion apparatus, safety equipment, crime / disaster prevention devices, etc.)**
Failure to follow this instruction may result in personal injury, economic loss or fire.
- 02. Do not use the unit in the place where flammable / explosive / corrosive gas, high humidity, direct sunlight, radiant heat, vibration, impact or salinity may be present.**
Failure to follow this instruction may result in explosion or fire.
- 03. Fix the unit on the metal plate.**
Failure to follow this instruction may result in personal injury or product and ambient equipment damage.
- 04. Do not connect, repair, or inspect the unit while connected to a power source.**
Failure to follow this instruction may result in fire.
- 05. Install the unit after considering counter plan against power failure.**
Failure to follow this instruction may result in personal injury, economic loss or fire.
- 06. Check 'Connections' before wiring.**
Failure to follow this instruction may result in fire.
- 07. Do not disassemble or modify the unit.**
Failure to follow this instruction may result in fire or electric shock.
- 08. Install the motor in the housing or ground it.**
Failure to follow this instruction may result in personal injury, fire or electronic shock.
- 09. Make sure to install covers on motor rotating components.**
Failure to follow this instruction may result in personal injury.
- 10. Do not touch the unit during or after operation for a while.**
Failure to follow this instruction may result in burn due to high temperature of the surface.
- 11. Upon occurrence of an error, disconnect the power source.**
Failure to follow this instruction may result in personal injury, fire or electronic shock.

⚠ Caution Failure to follow instructions may result in injury or product damage.

- 01. Use the unit within the rated specifications.**
Failure to follow this instruction may result in fire or product damage.
- 02. Use a dry cloth to clean the unit, and do not use water or organic solvent.**
Failure to follow this instruction may result in fire.
- 03. The motor may overheat depending on the environment. Install the unit at the well-ventilated environment and forced cooling with a cooling fan.**
Failure to follow this instruction may result in product damage or degradation by heat.
- 04. Keep the product away from metal chip, dust, and wire residue which flow into the unit.**
Failure to follow this instruction may result in fire or product damage.

Cautions during Use

- Follow instructions in 'Cautions during Use'. Otherwise, it may cause unexpected accidents.
- At low temperature, reducing the grease's consistency of ball-bearing and etc. causes the friction torque increment.
Start the motor gradually since motor's torque is in normal state.
- Be aware of backlash when positioning the motor in both CW/CCW directions.
Built-in gear type motor achieves low backlash due to high accuracy gear for positioning, but the problem may occur when positioning the motor in both CW/CCW directions.
In this case, the control is required to determine the position in either direction.
- Encoder shield cable must be connected to F.G. terminal.
- When wiring encoder cable, separate it from high voltage cable, power cable, etc. to prevent surge and inductive noise and keep the cable length as short as possible.
Failure to follow this instruction may result in raised cable resistance, residual voltage and output waveform noise.

- Maintain and inspect regularly the following lists.
 - Unwinding bolts and connection parts for the unit installation and load connection
 - Abnormal sound from ball-bearing of the unit
 - Damage and stress of lead cable of the unit
 - Connection error with driver
 - Inconsistency between the axis of motor output and the center, concentric (eccentric, declination) of the load, etc.
- This unit may be used in the following environments.
 - Indoors (in the environment condition rated in 'Specifications')
 - Altitude max. 2,000 m
 - Pollution degree 2
 - Installation category II

Cautions during Installation

- Follow instructions in 'Safety Considerations' and 'Cautions during Use'. Otherwise, it may cause unexpected accidents.
- Install the motor in a place that meets the certain conditions specified below. It may cause product damage if it is used out of following conditions.
 - Inside of the housing which is installed indoors (This unit is designed/manufactured for the purpose of attaching to equipment. Install a ventilation device.)
 - The place without contact with water, oil, or other liquid
 - The place without contact with strong alkali or acidity
 - The place with less electronic noise occurs by welding machine, motor, etc.
 - The place where no radioactive substances and magnetic fields exist. It shall be no vacuum status as well.
- Motor can be installed horizontally and vertically. Refer to 'Shaft Allowable Load along Installation Direction'.
- If a force (30 N) exceeding the specification is applied to the motor cable during installation, it may cause the contact failure and disconnection. If the excessive force or frequent cable movement is required, establish safety measures before use.
- In consideration of heat dissipation and vibration prevention, mount the motor as tight as possible against a metal panel with high thermal conductivity such as iron or aluminum.
- It may cause product damage if the motor's surface temperature is above 90°C. Motor can not be protected from overheating. When operating for a long time, install the product in a place with a heat protection function similar to a certain specification heat-proof plate (material: Aluminum, 240×240×5 mm).

Cautions during Connection with Load

- Do not disassemble or modify the motor shaft to connect with the load.
- Tighten the screw not to be unscrewed when connecting with load.
- Refer to 'Shaft Allowable Load along Installation Direction' and take care of potential shock when connecting with load.
- Connect the motor shaft and the load shaft to be parallel.
- If the center with the load is not aligned with the shaft, it may cause unexpected accidents such as severe vibration, shorten life cycle of the shaft bearing and shaft damage.
- When attaching coupling or pulley with motor shaft, be aware of damage on motor shaft and shaft bearing.

■ Coupling

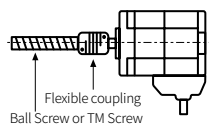

When connecting the load directly to the motor shaft, use a flexible coupling (ERB Series).

■ Pulley, Belt, Wire

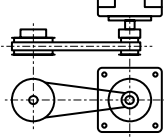

Connect the motor shaft and the line which connects the center of two pulleys to be perpendicular.

■ Gear

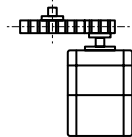

Connect the motor shaft to the center of gear teeth to be interlocked.

Troubleshooting

Malfunction	Troubleshooting
When motor does not excite	Check the connection status between controller and driver and pulse input specifications (voltage, width). Check the pulse and direction signal are connected correctly.
When motor rotates to the opposite direction of the designated direction	When the driver's RUN mode is 1-pulse input method, CCW input [H] is for forward, [L] is for backward. When the driver's RUN mode is 2-pulse input method, check CW and CCW pulse input are changed.
When motor drives unstable	Check the driver and motor are connected correctly. Check the driver pulse input specifications (voltage, width).

Ordering Information

This is only for reference, the actual product does not support all combinations. For selecting the specified model, follow the Autonics website.

Ai	-	M	-	①	②	③	-	④	⑤
----	---	---	---	---	---	---	---	---	---

① Frame size

Number: Frame size (unit: mm)

② Axial length

M: Medium

③ Encoder resolution

A: 10,000 PPR (2,500 PPR × 4-multiply)

④ Motor type

G: Built-in gear type
R: Built-in rotary actuator type

⑤ Reduction ratio

5: 1:5
7.2: 1:7.2
10: 1:10

Product Components

- Product
- Instruction manual

Sold Separately

- Motor + Encoder cable: C1D14M-□ (fixed type), C1DF14M-□ (flexible type)
- Flexible coupling: ERB Series

Dimensions

- Unit: mm, For the detailed drawings, follow the Autonics website.

■ Ai-M-42MA-G□

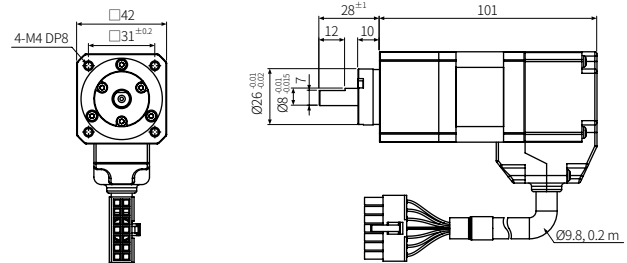

■ Ai-M-60MA-G□

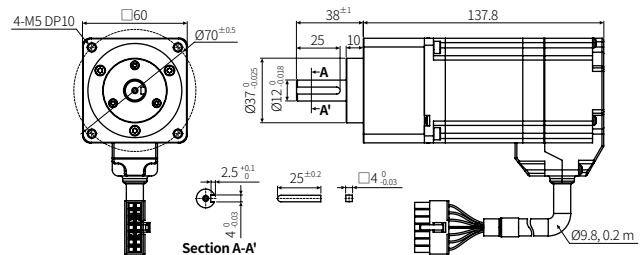

■ Ai-M-60MA-R□

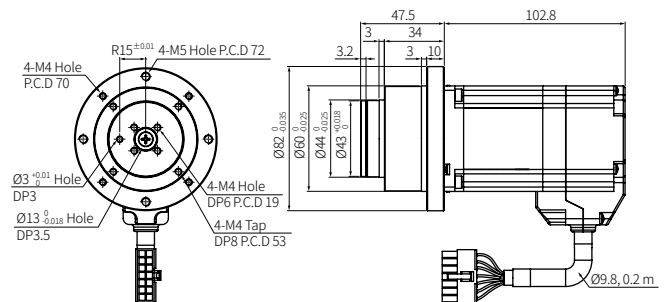

Installation Method

■ Built-in gear type

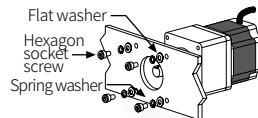

Frame size	Mounting plate thickness	Applied bolt
□ 42 mm	≥ 5 mm	M4
□ 60 mm	≥ 8 mm	M5

■ Built-in rotary actuator type

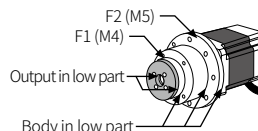

Frame size	Mounting plate thickness	Applied bolt	Tightening torque
□ 60 mm	≥ 8 mm	M4	2 N m
		M5	4.4 N m

Shaft Allowable Load along Installation Direction

■ Built-in gear type

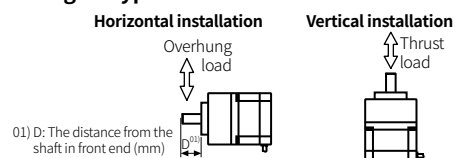

Frame size	Horizontal installation: Overhung allowable load [N]					Vertical installation: Thrust allowable load [N]
	D=0	D=5	D=10	D=15	D=20	
□ 42 mm	72	82	98	121	-	49
□ 60 mm	245	265	294	333	382	98

Specifications

Model	Ai-M-42MA-G5	Ai-M-42MA-G7.2	Ai-M-42MA-G10
Max. stop torque	1.5 N m	2 N m	2 N m
Rotor inertia moment	$54 \times 10^{-7} \text{ kg} \cdot \text{m}^2$		
Rated current	1.7 A / Phase		
Allowable torque	1 N m	1.5 N m	1.5 N m
Standard step angle	0.36°	0.25°	0.18°
Backlash	35 min (0.58°)		
Resistance	1.85 Ω / Phase ±10%		
Inductance	3.5 mH / Phase ±20%		
Unit weight (packaged)	≈ 0.58 kg (≈ 0.70 kg)		

Model	Ai-M-60MA-□5	Ai-M-60MA-□7.2	Ai-M-60MA-□10
Max. stop torque	7 N m	9 N m	11 N m
Rotor inertia moment	$490 \times 10^{-7} \text{ kg} \cdot \text{m}^2$		
Rated current	3.5 A / Phase		
Allowable torque	5 N m	6 N m	7 N m
Standard step angle	0.36°	0.25°	0.18°
Backlash	35 min (0.58°)		
Resistance	1.23 Ω / Phase ±10%		
Inductance	2.6 mH / Phase ±20%		
Unit weight (packaged) ⁰¹⁾	≈ 1.52 kg (≈ 1.68 kg)		
	≈ 1.60 kg (≈ 1.76 kg)		

01) Listed in order of Built-in gear type
Built-in rotary actuator type

Motor phase	2-phase
Run method	Bipolar
Insulation class	B type (130°C)
Insulation resistance	Between the motor coil and the case: ≥ 100 MΩ (500 VDC= megger)
Dielectric strength	Between the all charging part and the case: 500 VAC~ 50 / 60 Hz for 1 minute
Vibration	1.5 mm double amplitude at frequency 10 to 55 Hz in each X, Y, Z direction for 2 hours
Shock	≤ 50 G
Ambient temp.	0 to 50°C, storage: -20 to 70°C (no freezing or condensation)
Ambient humi.	20 to 85%RH, storage: 15 to 90%RH (no freezing or condensation)
Protection rating	IP30 (IEC standard)
Certification	CE ENEC
Stop angle error	± 0.09° (Full step, no load)
Shaft vibration	0.03 mm T.I.R.
Radial Movement ⁰¹⁾	≤ 0.025 mm T.I.R.
Axial Movement ⁰²⁾	≤ 0.01 mm T.I.R.
Shaft concentricity	0.05 mm T.I.R.
Shaft perpendicularity	0.075 mm T.I.R.

01) Amount of radial shaft displacement when applying radial load (25 N) to the end of the motor shaft

02) Amount of axial shaft displacement when applying axial load (50 N) to the motor shaft

Encoder type	Incremental Rotary Encoder
Power supply	5 VDC= ± 5% (ripple P-P: ≤ 5%)
Current consumption	≤ 50 mA (no load)
Resolution	10,000 PPR (2,500 PPR × 4-multiply)
Control output	Line driver output
Output phase	A, \bar{A} , B, \bar{B} , Z, \bar{Z}
Output waveform	Output duty rate: $\frac{T}{2} \pm \frac{T}{4}$, A-B phase difference $\frac{T}{4} \pm \frac{T}{8}$ (T = 1 cycle of A)
Inflow current	≤ 20 mA
Residual voltage	≤ 0.5 VDC=
Outflow current	≤ -20 mA
Output voltage	≥ 2.5 VDC=
Response speed	≤ 0.5 μs (based on cable length: 2 m, I sink = 20 mA)
Max. response frequency	300 kHz

Connectors

Motor + Encoder connector



Pin	Function	Pin	Function
1	GND	8	+5 VDC=
2	Encoder A	9	Encoder \bar{A}
3	Encoder B	10	Encoder \bar{B}
4	Encoder Z	11	Encoder \bar{Z}
5	PE	12	N·C
6	Motor A	13	Motor B
7	Motor \bar{A}	14	Motor \bar{B}

Suitable specifications

Type	Connector specifications	Manufacture
Motor + Encoder connector	5557-14R (connector terminal: 5556T)	Molex

Encoder Control Output Diagram

Line driver output

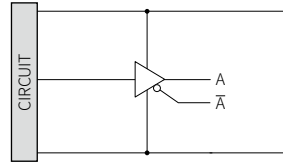

Encoder Output Waveforms

- The rotation direction is based on facing the shaft, and it is clockwise (CW) when rotating to the right.
- Output duty rate: $\frac{T}{2} \pm \frac{T}{4}$ (T = 1 cycle of A)
- Phase difference between A and B: $\frac{T}{4} \pm \frac{T}{8}$ (T = 1 cycle of A)

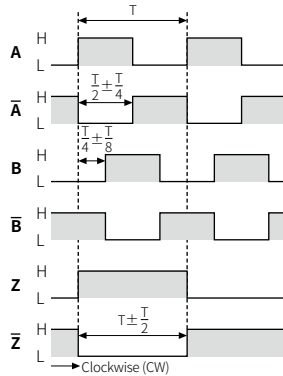

Connection Diagram

- The wiring colors for each phase (coil) and lead-wire are as follows.

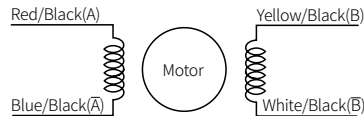

Application Examples of Built-In Rotary Actuator Type

Index table

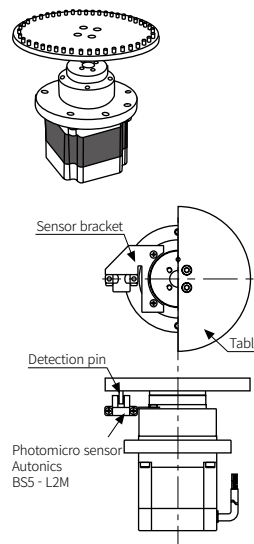

Floating arm

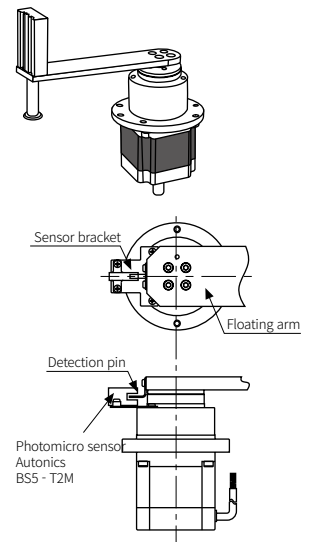

Motor Characteristics

■ Ai-M-42MA-G5

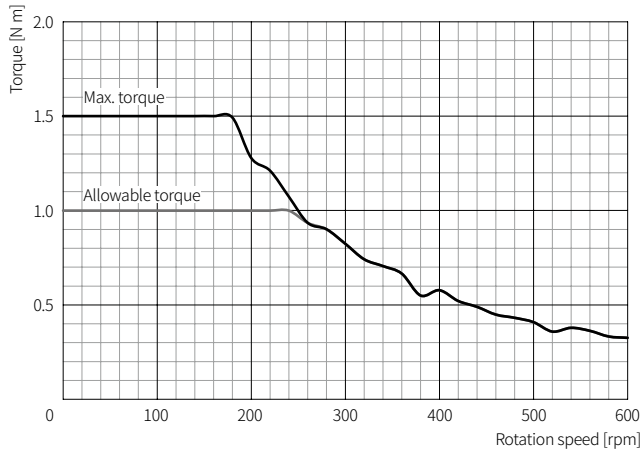

■ Ai-M-42MA-G7.2

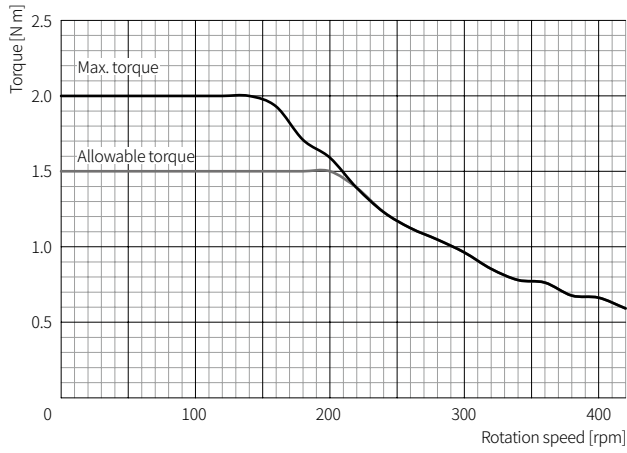

■ Ai-M-42MA-G10

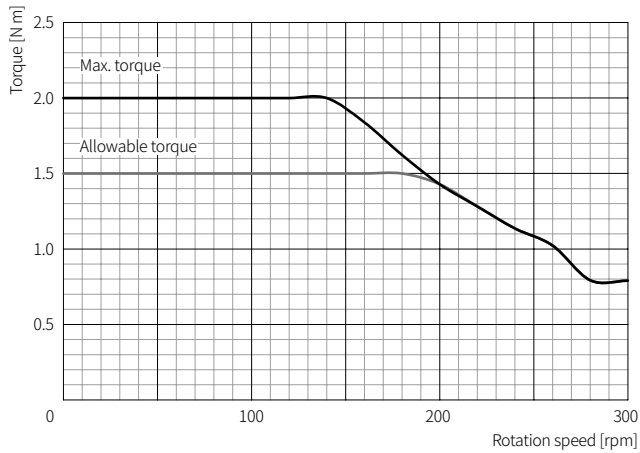

■ Ai-60MA-□5

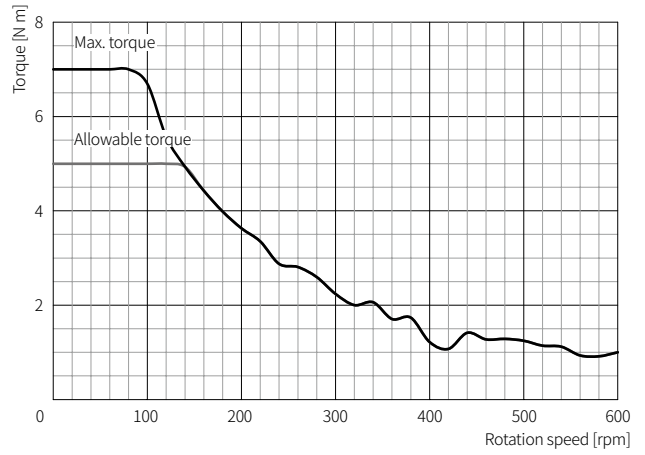

■ Ai-60MA-□7.2

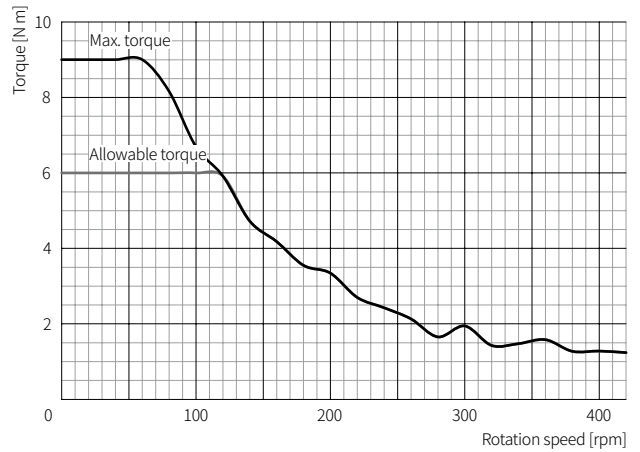

■ Ai-60MA-□10

